

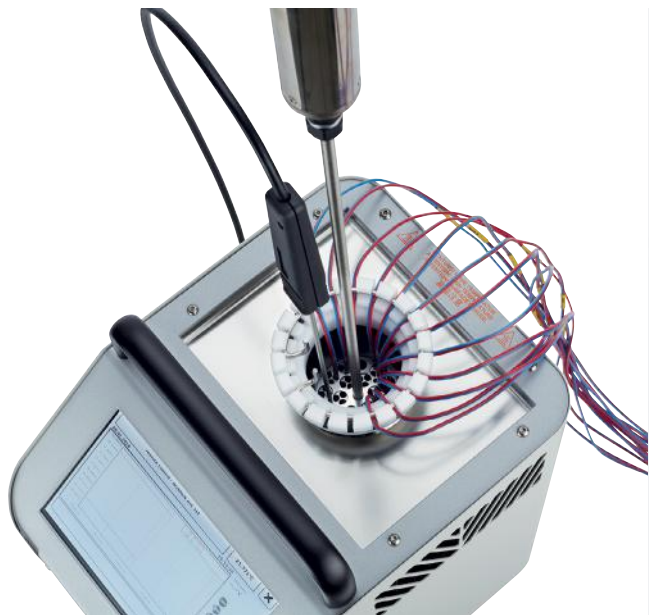

SUBSIDIARY OF AMPHENOL

Temperature Calibration Devices

DRY BLOCK, LIQUID BATH, AND TEMPERATURE STANDARDS



Calibrator Overview

Kaye has a full line of calibrators that can fit nearly any application in the pharmaceutical or biotech setting. Our dry block calibrators, liquid baths, and IRTD temperature standards provide the most precise accuracy on the market, guaranteeing that you can rely on Kaye's trusted instruments.

For the past 65+ years, professionals across the world have trusted Kaye products to deliver the most accurate measurements that are also traceable and secure. So, when you need to calibrate your thermocouples, wireless data loggers, or even verify

your IRTD probe, rest assured that we've got the solution for you.

There is rarely a one-size-fits-all solution when it comes to calibrators, so at Kaye, we want to ensure that our customers get the calibrator that will fulfill their needs. The tables in this document display specific parameters and specifications for each of our calibrators so you can have a clear understanding of which calibrator would be best for your metrology lab or pharmaceutical thermal validation application.

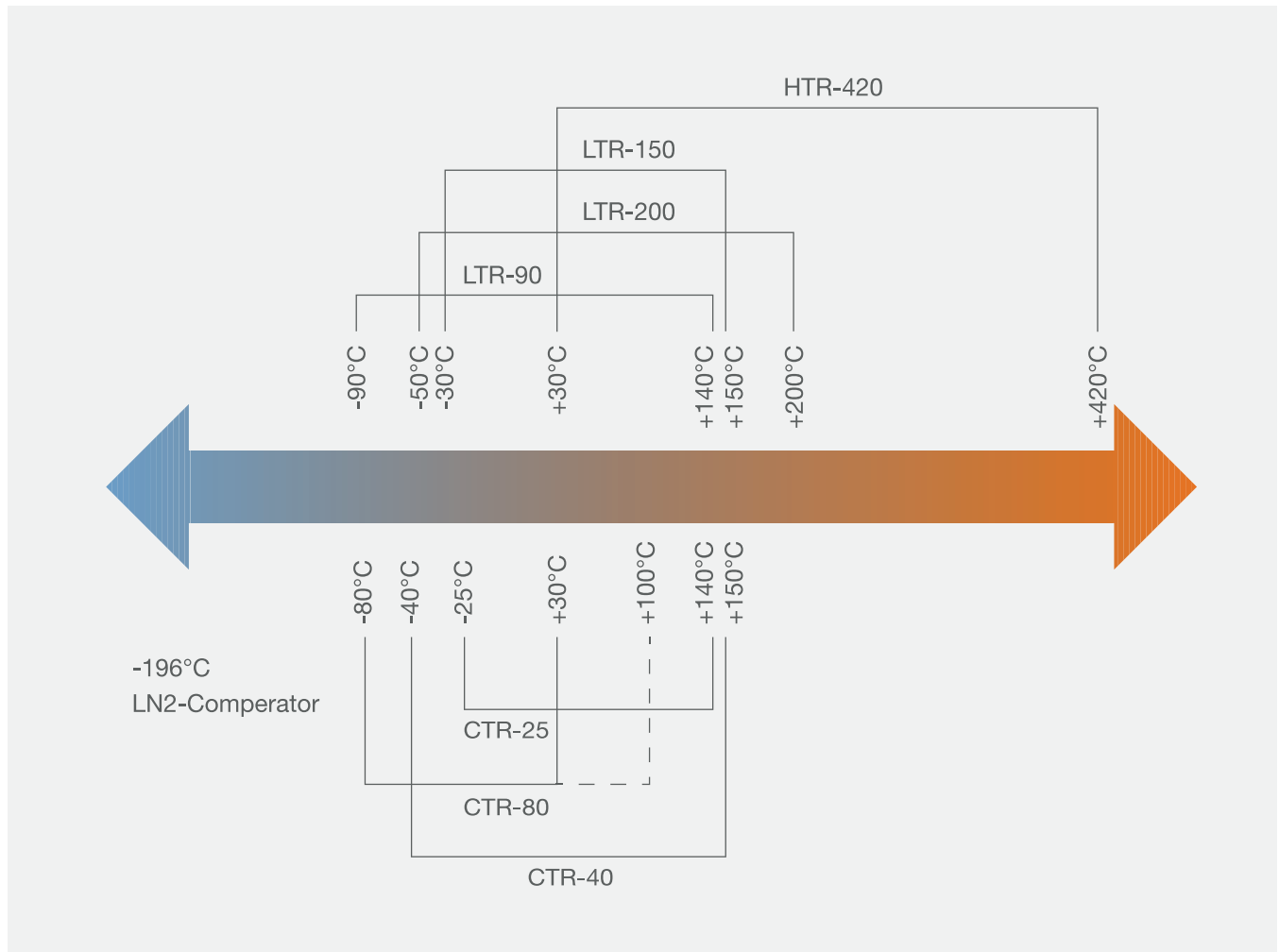

Temperature coverage by Kaye Dry-Block Calibrators and Calibration Baths

Liquid Nitrogen Comparator

PERFECT DEVICE FOR EASY TEMPERATURE CALIBRATIONS AT -196°C

The Kaye Liquid Nitrogen (LN2) Comparator is a device specifically designed to address the calibration needs for extreme cold temperatures. With the ability to calibrate up to 48 sensors at a time, it addresses capacity and flexibility needs for thermal calibration at cryogenic temperatures. It makes the calibration process much more reliable and secure compared to other methods used in the industry. It is often used in combination with other Kaye baths like the LTR-90, so multiple calibration and verification points can be performed at cold temperatures.





Using a Kaye IRTD and a Kaye Validator, the process is semi-automated to make it easier for the user, and a calibration or verification report can be automatically generated at the end of the process.

The LN2 Comparator provides the ability to run a comparison calibration at temperatures around -196°C . It can be used to calibrate thermocouples and other temperature probes against the Kaye IRTD. The comparator is designed to be easy to use. The simple design requires no electrical power for operation. It simply uses liquid nitrogen to run calibrations at -196°C , the boiling point of nitrogen.



Dry Block Calibrators

SPECIFICATIONS

	LTR-90	LTR-150	LTR-200	HTR-420
				
Temperature Range	-90°C to 140°C	-30°C to 150°C	-50°C to 200°C	30°C to 420°C
Temperature Stability	±0.01°C	±0.01°C	±0.01°C	±0.01°C
Typical Heat-Up Time	-90°C to 25°C: 15 min 25°C to 140°C: 14 min	20°C to 121°C: 30 min -30°C to 20°C: 20 min	25°C to 140°C: 7 min 25°C to 200°C: 10 min -50°C to 25°C : 7 min	30°C to 100°C: 7 min 30°C to 350°C: 20 min
Typical Cool-Down Time	23°C to -90°C: 80 min 140°C to 20°C: 60 min	20°C to -25°C: 45 min 121°C to 20°C: 30 min	140°C to 25°C: 13 min 25°C to -50°C: 27 min	350°C to 125°C: 20 min 350°C to 50°C: 40 min
Access Opening/ Well configuration	Interchangeable Insert Ø 30 mm (Ø 1.18 in) 160 mm depth (6.3 in)	Interchangeable Insert Ø 60 mm (Ø 2.36 in) 170 mm depth (6.7 in)	Interchangeable Insert Ø 27.7 mm (Ø 1.09 in) 136 mm depth (5.35 in)	Interchangeable Insert Ø 60 mm (Ø 2.36 in) 170 mm depth (6.7 in)
Dimensions (H x W x D)	380mm x 205mm x 480mm	380mm x 210mm x 300mm	380 mm x 210 mm x 300 mm	345mm x 215mm x 290mm
Power	115V 60 Hz 230V 50 Hz Approx. 350 watts	100–240V 50/60Hz Approx. 375 watts	100–240V 50/60Hz Approx. 550 watts	100–240V 50/60Hz Approx. 1,000 watts
Max # of thermocouples	25	48	24	48
Max # of IRTDs	1	3	1	3

LTR-90

ULTRA-COOL DRY BLOCK CALIBRATOR -90°C TO 140°C

The Kaye LTR-90 is an ultra-cool dry well calibrator designed for portability and ease of operation. Operating from -90°C to +140°C, it delivers fast response, high stability, and automated sensor calibration for ultra-low temperature applications.

Features & benefits

- Stirling cooler technology: reaches -90°C in 80 minutes
- Temperature stability of $\pm 0.01^\circ\text{C}$
- Axial uniformity of $\pm 0.05^\circ\text{C}$ across the full range
- Software interface with Kaye Validator for automatic sensor calibration utility
- Custom block design to accommodate 1 reference probe (IRTD) and 25 thermocouples or sensors
- Rubber insulator cap to prevent frost buildup

LTR-200

DRY BLOCK HYBRID TEMPERATURE CALIBRATOR | -50°C TO 200°C

The Kaye LTR-200 is a calibration dry block specially designed to meet the capacity and flexibility requirements for thermal validation. This device possesses the ability to calibrate up to 24 sensors simultaneously, saving hours of time and effort during the calibration or verification of validation sensors.

Features & benefits

- Operating range of -50°C to 200°C, with temperature stability of up to $\pm 0.01^\circ\text{C}$ and uniformity of up to $\pm 0.1^\circ\text{C}$
- Superb heating and cooling times
- Calibration of up to 24 sensors using the dry block insert, saving hours of time
- Software interface compatible with all existing Kaye products, including IRTD, Validator 2000, Validator AVS, ValProbe (RT), and RF ValProbe, enabling automatic/manual calibrations
- User-friendly touchscreen interface
- Universal power supply 100 – 240 VAC / 50 – 60 Hz
- Additional inserts available for calibrating specialty or process probes

LTR-150

DRY BLOCK AND LIQUID BATH ALL-IN-ONE TEMPERATURE CALIBRATOR | -30°C TO 150°C

From its ability to calibrate 48 thermocouples at one time to its versatility to function as a dry block, liquid bath, or surface calibrator, the LTR-150 saves hours of time and effort when calibrating or verifying validation sensors.

Features & benefits

- Uniformity of up to $\pm 0.1^\circ\text{C}$
- Fast heating and cooling times
- Thermocouple fixture for easy handling of up to 48 TCs
- Dry block inserts designed to accommodate thermocouples, IRTD, ValProbe (RT) flexible/bendable as well as RF ValProbe probes
- Software interface for all existing Kaye products (IRTD, Validator 2000, Validator AVS, ValProbe (RT), and RF ValProbe) with features for automatic/manual calibrations
- Liquid micro bath tub with sensor cage and magnetic stirrer can be used for thermocouples, special process probes, as well as ValProbe RT rigid loggers

HTR-420

DRY BLOCK TEMPERATURE CALIBRATOR 30°C TO 420°C

The Kaye HTR-420 is the most advanced high-temperature calibrator and is compatible with the Validator 2000, Validator AVS, ValProbe (RT), or RF ValProbe software for automatic sensor calibration.

Features & benefits

- Uniformity of up to $\pm 0.1^\circ\text{C}$
- Fast heating and cooling times
- Software interface for all existing Kaye products (IRTD, Validator 2000, Validator AVS, ValProbe (RT), and RF ValProbe) with features for automatic/manual calibrations
- Additional inserts available for calibrating specialty or process probes

Inserts and Fixtures

LTR-90



LTR-150

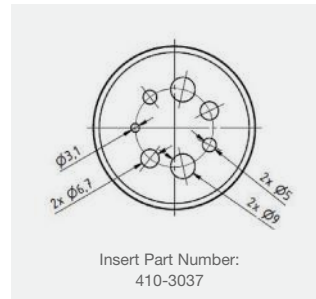
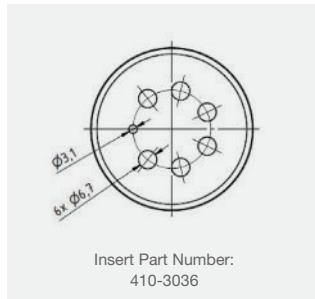
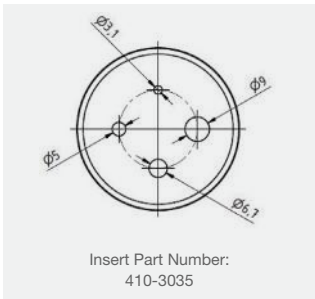
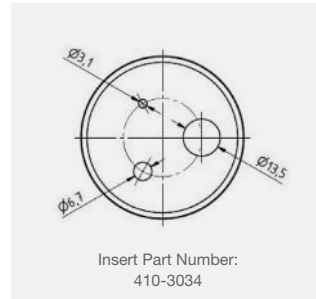
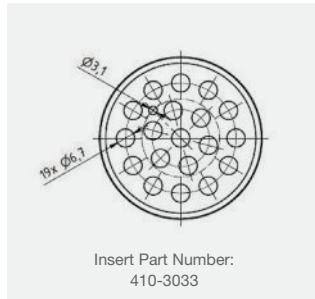
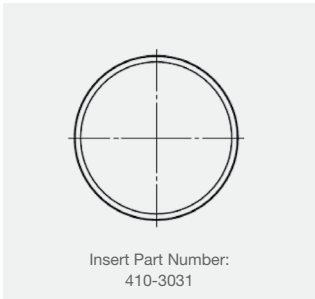

LTR-200

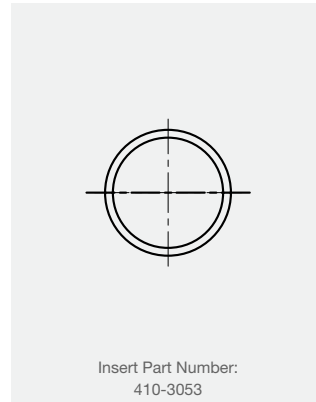
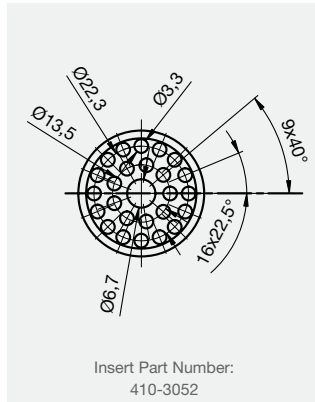
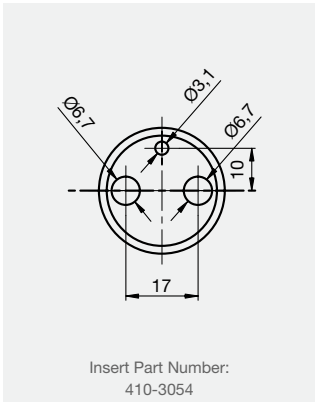

Inserts and Fixtures

HTR-420

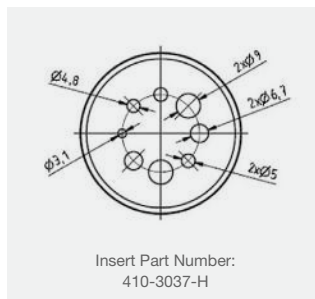
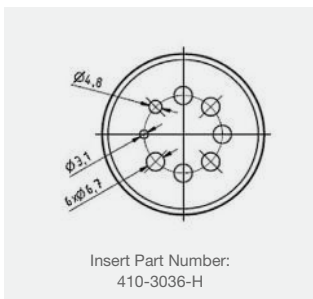
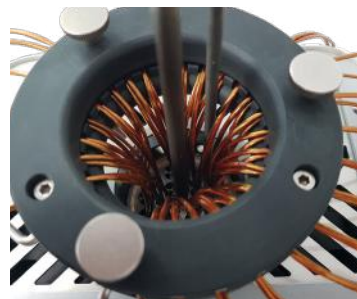
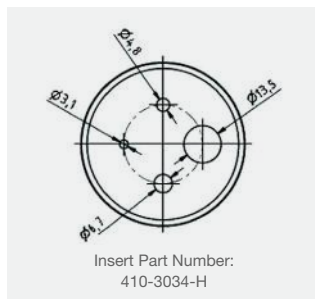
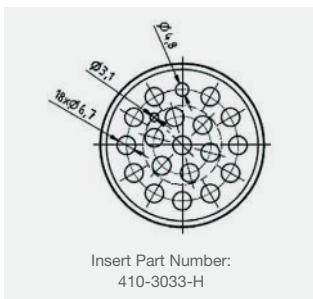
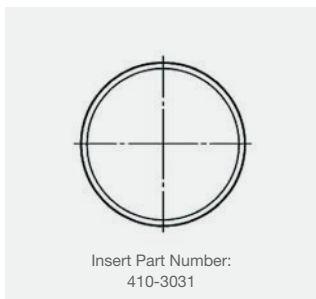

Shipping Cases

SAFE STORAGE AND TRANSPORTATION FOR YOUR KAYE EQUIPMENT

Features & benefits

- Robust, secure, and practical, with shock protection during transport
- Can be used as a trolley for easy transportation
- Provides safety during shipments and internal transportation
- Safe shipment and transport for annual service
- Specific storage inserts for all accessories/ documentation
- Protects against moisture, dust, and pollution – waterproof
- Provides the best storage when the system is not in use
- Can be locked to prevent theft and unauthorized usage



Liquid Calibration Baths

SPECIFICATIONS

	CTR-25	CTR-40	CTR-80
			
Temperature Range	-25°C to 140°C	-40°C to 150°C	-80°C to 30°C (100°C)
Temperature Stability	0.01°C	±0.005°C at -40°C (oil)	±0.006°C at -80°C (halocarbon)
Typical Heat-Up Time	25°C to 140°C: 55 min	25°C to 150°C: 60 min	-80°C to 25°C: 60 min
Typical Cool-Down Time	140°C to 25°C: 45 min	25°C to -40°C: 110 min	25°C to -80°C: 120 min
Access Opening/ Well configuration	111mm x 111mm (4.4" x 4.4") Tank 2.5l	172mm x 94mm (6.8" x 3.7") Tank 9.2l	86mm x 114mm (3.25" x 4.5") Tank 3.8l
Dimensions (H x W x D)	382mm x 242mm x 400mm	584 mm x 305 mm x 622 mm	762 x 305 x 610mm
Power	115V 50 Hz or 60 Hz 230V 50 Hz or 60 Hz Approx. 1,150 watts	115V 60 Hz 230V 50 Hz Approx. 1,400 watts	115V 60 Hz 230V 50 Hz Approx. 1,700 watts
Max number of rigid ValProbe loggers	10	16	3

Additional fixtures available for:

- CTR-40 – can hold up to 20 freeze dryer loggers
- CTR-80 – can hold up to 12 freeze dryer loggers

CTR-25

PORTABLE LIQUID CALIBRATION BATH -25°C TO 140°C

The CTR-25 was designed to address portability, capacity, speed, and accuracy requirements not normally found in competitive liquid baths. The CTR-25 is ideally suited for verifications of up to 10 Kaye ValProbe or ValProbe RT Loggers, as well as various-sized process sensors.

Features & benefits

- Uniformity of up to $\pm 0.02^\circ\text{C}$
- Firmware supports automatic/manual verifications of ValProbe loggers
- Compressor-free unit – operates with modern Peltier technology
- Stainless steel casing withstands harsh sterilizing chemicals
- Large front panel display with intuitive controls
- Large 2.5L tank with up to 6" (15.24cm) depth can accommodate a wide range of sensor types



CTR-40

LIQUID CALIBRATION BATH -40°C TO 150°C

The advanced design of the CTR-40 combines excellent temperature stability and uniformity with a temperature range of -40 to 150°C to address ValProbe applications. The generous 9.2-liter tank and specially designed ValProbe immersion basket accommodate up to 16 ValProbe loggers, making calibration or verification a quick and easy process.

Features & benefits

- Large capacity for multiple and different size sensors
- Indicates temperature to 0.01°C resolution
- Automates calibration when used with all Kaye products
- Quiet operation

CTR-80

ULTRA-LOW TEMPERATURE BATH -80°C TO 30°C

The CTR-80 bath is the ideal unit for calibrating temperature sensors used in freeze dryers, freezers, and ultra-low cryo units. Operating from -80 to 30°C, the CTR-80 brings fast response and high stability to your cold temperature applications.

Features & benefits

- Large capacity for multiple and different size sensors
- Uniformity of up to $\pm 0.008^\circ\text{C}$
- Indicates temperature to 0.01°C resolution
- Automates calibration when used with all Kaye products
- Quiet operation

Temperature Standard IRTD-400

HIGH-ACCURACY TRACEABLE TEMPERATURE STANDARD
-196°C TO 420°C

During sensor calibration/verification, sensors are compared against the IRTD, and offsets are automatically calculated and stored. The broad temperature range from -196°C to 420°C enables it to be used in virtually all temperature validation applications.

Features & benefits

- Accuracy over range $\pm 0.025^{\circ}\text{C}$
- Resolution 0.001°C
- Sensor element: 200 Ohm Platinum sensor
- Sheath material: Inconel™ 600
- Calibration traceable to NIST or PTB
- Ambient temperature range: 0 to 60°C (32 to 140°F)
- Humidity: 0 to 95% non-condensing
- Dimensions:
 - Overall length: 603mm (23.75")
 - Grip: 89mm x 32mm (3.5" x 1.25")
 - Sensor sheath: 457mm x 6.35mm (18" x 0.25")

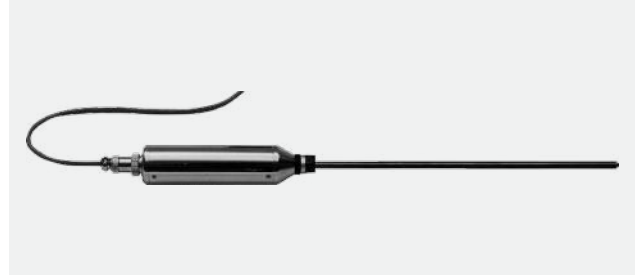

IRTD Laboratory Calibration

Every Kaye IRTD is factory calibrated in our ISO 17025 accredited laboratory by a team of professionals who ensure the reference device is precise and accurate. The IRTD is tested in multiple baths from -196°C up to 420°C, with an accuracy of up to $\pm 0.005^{\circ}\text{C}$. Data is recorded at various temperature points to guarantee repeatable and traceable results. Regulatory bodies recommend this robust procedure be performed annually to ensure that your temperature standard has not drifted.

IRTD and Kaye Validation Systems

Use the IRTD as a traceable and highly accurate standard to verify your qualification studies. The IRTD comes configured to work seamlessly with all Kaye validation products, such as the Validator AVS, ValProbe RT, RF ValProbes, and Kaye baths. For wired qualifications using a Validator AVS, users must perform a verification to ensure their thermocouples are working properly. The IRTD is used as a temperature standard in combination with several Kaye baths, such as the LTR-150 or HTR-420, to verify the accuracy of the thermocouples.

IRTD Stand-Alone Software

EASY AND FLEXIBLE SOFTWARE FOR DIRECT IRTD COMMUNICATION

For independent applications in calibration laboratories, the IRTD Win Console Software can be used to communicate with up to 2 IRTDs at the same time. It's a convenient interface enabling you to track probe stability, numerically and graphically, log data to a file, compare IRTDs, and much more. The software's flexibility permits use with both standard PCs and touch screens.

Features & benefits

- State-of-the-art look and feel
- Designed for Win8.1 and Win10
- Accepts up to 2 IRTDs
- Communicates via USB ports
- Easy-to-use touch screen
- Graph for each IRTD
- Variable log rate
- Accepts IRTD cable of Validator 2000 and Validator AVS



IRTD Display

STAND-ALONE DISPLAY TO CONNECT TO KAYE IRTD

The Kaye IRTD touchscreen display is a stand-alone unit designed to connect to up to two IRTDs. This provides real-time temperature data in a user-friendly format. The advanced display unit combines the accuracy and reliability of IRTDs with the convenience and interactivity of a touchscreen, making temperature monitoring easier and more efficient.

Features & benefits

- Touchscreen: 4.3"
- Display readings for up to two Kaye IRTD reference probes in three resolutions
- Shows delta between the two connected IRTDs
- Scan rate from 5 to 60 seconds
- Supports both types of IRTD connector cables
- Supports the change of IRTD settings (address, units, ...)

- Supports logging data captured to internal memory (for 1 IRTD and for 2 IRTDs)
- Unit is powered externally and supports an external power bank for 5V USB supply, if required



Visit our website:

Kaye representative contact:

Request a demo:

EUROPE, MIDDLE EAST, AFRICA AND ASIA

Amphenol Advanced Sensors Germany GmbH
Sinsheimer Strasse 6
D-75179 Pforzheim

T: +49 (0) 7231-14 335 0

F: +49 (0) 7231-14335 29

Email: kaye@amphenol-sensors.com
www.kayeinstruments.com

USA/AMERICAS

Amphenol Thermometrics, Inc.
967 Windfall Road
St. Marys, PA 15857

T: +1(814) 834-9140

F: +1(814) 781-7969

Email: kaye-us@amphenol-sensors.com
www.kayeinstruments.com

INDIA

Amphenol Interconnect India Pvt Ltd.
Plot no. 6, Survey No.64
Software Units layout

MAHAVEER TECHNO PARK

Hitech City, Madhapur

Hyderabad, Telangana – 500081

T: +91 40 33147100

Email: kaye-india@amphenol-sensors.com
www.kayeinstruments.com

CHINA

Amphenol (Changzhou) Connector Systems Co., Ltd
Building 10, Jintong Industrial Park,
No. 8 Xihu Road, Wujin High-Tech Development Zone,
Changzhou, Jiangsu 213164

T: 0086-519-83055197

www.kayeinstruments.com

AAS-BRK-20001-A



Warranty and disclaimer: The information mentioned on documents are based on our current tests, knowledge and experience. Because of the effect of possible influences in an application of the product, they do not exempt the user from their own tests, checks and trials. A guarantee of certain properties or a guarantee for the proper suitability of the product for a specific, especially permanent application can not be derived from our data. Liability is therefore excluded to that extent permitted by law. Any proprietary rights of third parties as well as existing laws and regulations must be observed by the recipient of the product on his own responsibility.

© 2024 Amphenol Corporation. All Rights Reserved. Specifications are subject to change without notice. Other company names and product names used in this document are the registered trademarks or trademarks of their respective owners.