

LTR-200



DRY BLOCK HYBRID
TEMPERATURE CALIBRATOR
FLEXIBLE – EASY TO USE
(-50°C TO 200°C)

The Kaye LTR-200 is the newest addition to our extensive range of advanced calibration dry blocks specifically designed to meet the capacity and flexibility requirements for thermal validation. This device possesses the ability to calibrate up to 24 sensors simultaneously, saving hours of time and effort during the calibration or verification of validation sensors. Due to its extensive range, this hybrid calibrator is ideal for calibrating temperature sensors utilized in cold rooms, incubators, autoclaves, freezers, and cryo units. The newly introduced Dry Block Temperature Calibrator is compatible with the Validator 2000, Validator AVS, ValProbe (RT) or RF ValProbe software for automatic sensor calibration. It can also function independently through its user-friendly touchscreen display.

FEATURES & BENEFITS

- Operating range of -50°C to 200°C, with temperature stability of up to 0.01°C and uniformity of up to 0.1°C
- Superb heating and cooling times
- Calibration of up to 24 sensors using the dry block insert, saving hours of time
- Dry block inserts are designed to accommodate thermocouples, IRTD, as well as ValProbe (RT) flexible/bendable probes
- Special TC fixture for easy handling of up to 24 thermocouples
- Software interface compatible with all existing Kaye products, including IRTD, Validator 2000, Validator AVS, ValProbe (RT) and RF ValProbe, enabling automatic/manual calibrations
- User-friendly touchscreen interface
- Universal power supply 100 – 240 VAC / 50 – 60 Hz
- Additional inserts available for calibrating specialty or process probes

Flexibility and Efficiency with the LTR-200

The standard insert – included with every LTR-200 – allows the calibration of up to 24 thermocouples (TCs) and the immersion of one IRTD.

The LTR-200 comes equipped with a specially designed sensor holder. This feature not only guarantees easy installation but also ensures that the sensors remain in

position for maximum accuracy during calibration or verification. The calibrator boasts remarkable flexibility, allowing the dry block insert to be replaced within seconds.

A variety of inserts are available to provide the maximum flexibility needed to accommodate different sensors of varying diameters and shapes.



FAST STABILIZATION

The specially designed controller enables a swift stabilization time with minimal temperature overshooting. This ensures a rapid response to setpoint changes and extremely stable setpoints to within a few thousandths of a degree.

FAST HEATING

The unique heating concept specifically designed for the LTR-200 provides a remarkably rapid heating rate, surpassing the efficiency of other models. This feature ensures high throughput and efficient calibrations, thereby saving hours of labor and reducing costs.

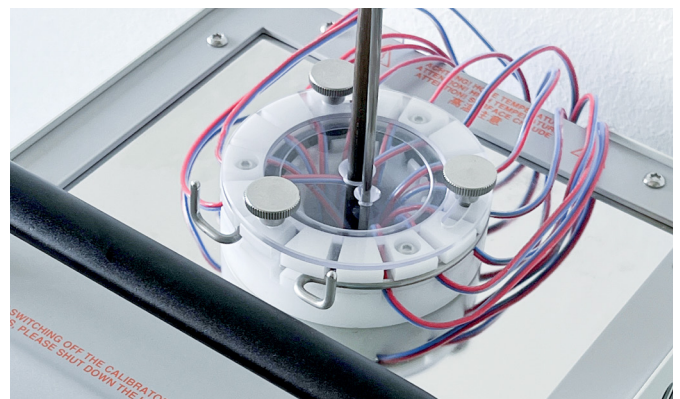

LTR-200 Specifications

TECHNICAL DATA

MODEL

Model	LTR-200
Control Sensor	External

DRY BLOCK

Temperature Range*	-50°C to 200°C (-58°F to 392°F)
Accuracy	±0.1°C (±0.18°F)
Stability	±0.010°C (±0.018°F)
Uniformity	0.1°C (0.18°F)

HEATING/COOLING TIME

25°C to 140°C	7 minutes
25°C to 200°C	10 minutes
-50°C to 25°C	7 minutes
140°C to 25°C	13 minutes
25°C to -50°C	27 minutes

BLOCK DIMENSIONS

Diameter	Ø 27.7 mm (Ø 1.09 in)
Depth	136 mm (5.35 in)

DISPLAY UNIT

Display Unit	7" Color-Touchscreen
Resolution	0.1/0.01/0.001 – °C/°F/K

GENERAL DATA

Interface	Serial to Validator/Ethernet/3 X USB
Dimensions	210 mm x 300 mm x 380 mm
Weight (approximate)	16 kg/35 lbs
Power Supply	100 - 240VAC, 50/60Hz
Power Consumption	550W

* at an ambient temperature of 20°C/68°F

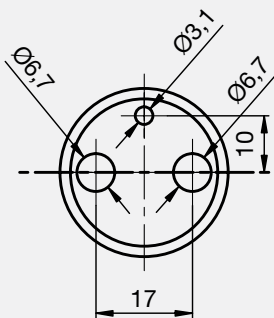

Insert Part Number:
410-3054

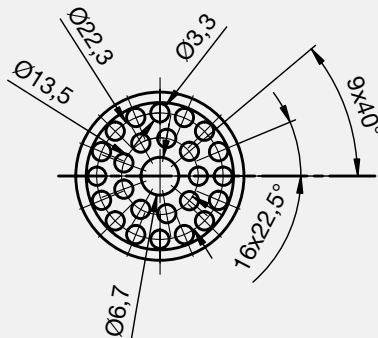

Insert Part Number:
410-3052

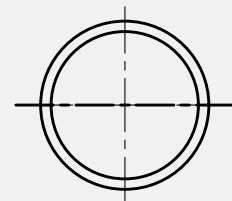

Insert Part Number:
410-3053

PART NUMBER

DESCRIPTION

X0350

LTR-200 Temperature Calibrator includes:

- 24 sensor Dry Block Insert
- Special thermocouple fixture
- Insert exchange tool
- USB/serial adapter cable
- External control reference probe
- US and EU power cables (100-240VAC 50/60 Hz)
- User manual
- Calibration certificate



ACCESSORIES

412-3114

Thermocouple Fixture



441-1053

LTR-200 Shipping Case



Kaye Representative contact:

Request a demo:

EUROPE, MIDDLE EAST, AFRICA AND ASIA
 Amphenol Advanced Sensors Germany GmbH
 Sinzheimer Strasse 6
 D-75179 Pforzheim
T: +49 (0) 7231-14 335 0
F: +49 (0) 7231-14335 29
Email: kaye@amphenol-sensors.com

USA/AMERICAS
 Amphenol Thermometrics, Inc.
 967 Windfall Road
 St. Marys, PA 15857
T: +1(814) 834-9140
F: +1(814) 781-7969
Email: kaye-us@amphenol-sensors.com

INDIA
 Amphenol Interconnect India Pvt Ltd.
 Plot no. 6, Survey No.64 | Software Units layout
 MAHAVEER TECHNO PARK
 Hitech City, Madhapur | Hyderabad,
 Telangana – 500081 | **T:** +91 40 33147100
Email: kaye-india@amphenol-sensors.com

CHINA
 Amphenol (Changzhou) Connector
 Systems Co., Ltd, Building 10,
 Jintong Industrial Park, No. 8 Xihu Road,
 Wujin High-Tech Development Zone,
 Changzhou, Jiangsu 213164
T: 0086-519-83055197



Warranty and disclaimer: The information mentioned on documents are based on our current tests, knowledge and experience. Because of the effect of possible influences in an application of the product, they do not exempt the user from their own tests, checks and trials. A guarantee of certain properties or a guarantee for the proper suitability of the product for a specific, especially permanent application can not be derived from our data. Liability is therefore excluded to that extent permitted by law. Any proprietary rights of third parties as well as existing laws and regulations must be observed by the recipient of the product on his own responsibility.

© 2024 Amphenol Corporation. All Rights Reserved. Specifications are subject to change without notice. Other company names and product names used in this document are the registered trademarks or trademarks of their respective owners.

AAS-DSK-07003